

# REVOLVED

## MATERIALIEN

**Korb:** stahl epoxiert in schwarzem Strukturlack

**Ring:** schwarzen Kunststoffbodenschutzring

## MODELLE

Revolved L

- L 1
- L 2
- L 3
- L 1 tumble lid
- L 1 flame retardant
- L 1 open top

Revolved XL

- XL 1
- XL 2
- XL 3

Revolved waste bin

Revolved umbrella bin

## 3D-FILES UND HR-BILDER

[www.van-esch.com/de/downloads](http://www.van-esch.com/de/downloads)

## REVOLVED L



### L 1

Liter: 70L  
Gewicht: 4,9 kg



### L 2

Liter: 35+35L  
Gewicht: 4,9 kg



### L 3

Liter: 15+15+40L  
Gewicht: 4,9 kg



### L 1 tumble lid

Liter: 70L  
Gewicht: 4,9 kg



### L 1 flame retardant

Liter: 75L  
Gewicht: 7,5 kg



### L 1 open top

Liter: 70L  
Gewicht: 5,5 kg

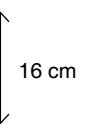

## REVOLVED XL

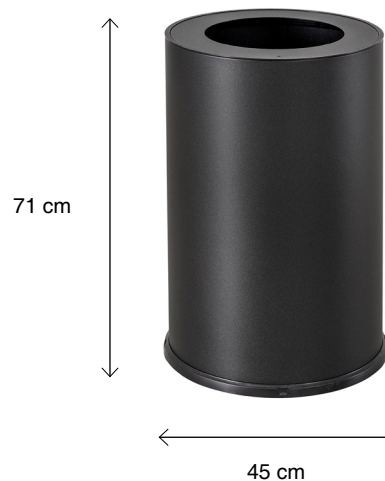

### XL 1

Liter: 100L  
Gewicht: 6,5 kg



### XL 2

Liter: 50+50L  
Gewicht: 6,5 kg



### XL 3

Liter: 33+33+33L  
Gewicht: 6,5 kg

### REVOLVED WASTE BIN

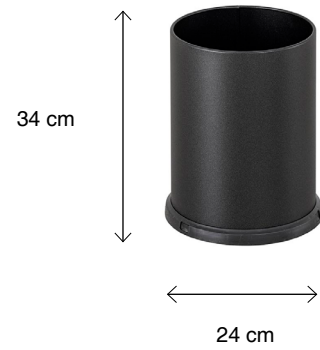

**waste bin**  
Liter: 15L  
Gewicht: 1,8 kg

### REVOLVED UMBRELLA BIN



**umbrella bin**  
Gewicht: 2,5 kg  
Inklusive: Tropfmülde

### REVOLVED WASTE STREAM STICKERS



Bioabfall



Papier



Plastik



Restmüll